

PACKAGED HEAT PUMP 13.4 SEER2 2 TO 5 TONS



Contents

Nomenclature.....	2
Product Specifications.....	3
Expanded Cooling Data.....	4
Expanded Heating Data.....	16
Airflow Data.....	19
Heat Kit Electrical Data.....	20
Dimensions.....	21
Wiring Diagram.....	22
Accessories.....	23

Standard Features

- Energy-efficient scroll compressor
- Multi-speed ECM indoor blower motor
- Quiet horizontal discharge
- All-aluminum evaporator coil
- Copper tube/aluminum fin condenser coil
- Totally enclosed, permanently lubricated condenser fan motor
- Fully charged system
- Electric heat kit available as a field-installed option
- AHRI certified; ETL listed

Cabinet Features

- Heavy-gauge galvanized-steel cabinet with architectural gray powder-paint finish
- Aluminum foil-facing internal insulation reinforced with fiberglass scrim
- Fully insulated blower compartment with convenient access panels
- Meets cabinet air leakage requirements when tested in accordance with ASHRAE standard 193
- Louvered condenser coil protection
- One footprint for all tonnages
- When properly anchored, meets the 2020 Florida Building Code unit integrity requirements for hurricane-type winds (Anchor bracket kits available.)

10 YEAR PARTS LIMITED WARRANTY*



COMPANY WITH QUALITY SYSTEM CERTIFIED BY DNV GL
= ISO 9001 =

COMPANY WITH ENVIRONMENTAL SYSTEM CERTIFIED BY DNV GL
= ISO 14001 =



* Complete warranty details available from your local dealer or at www.goodmanmfg.com. To receive the 10-Year Parts Limited Warranty, online registration must be completed within 60 days of installation. Online registration is not required in California or Quebec. The duration of warranty coverages in Texas differs in some cases.

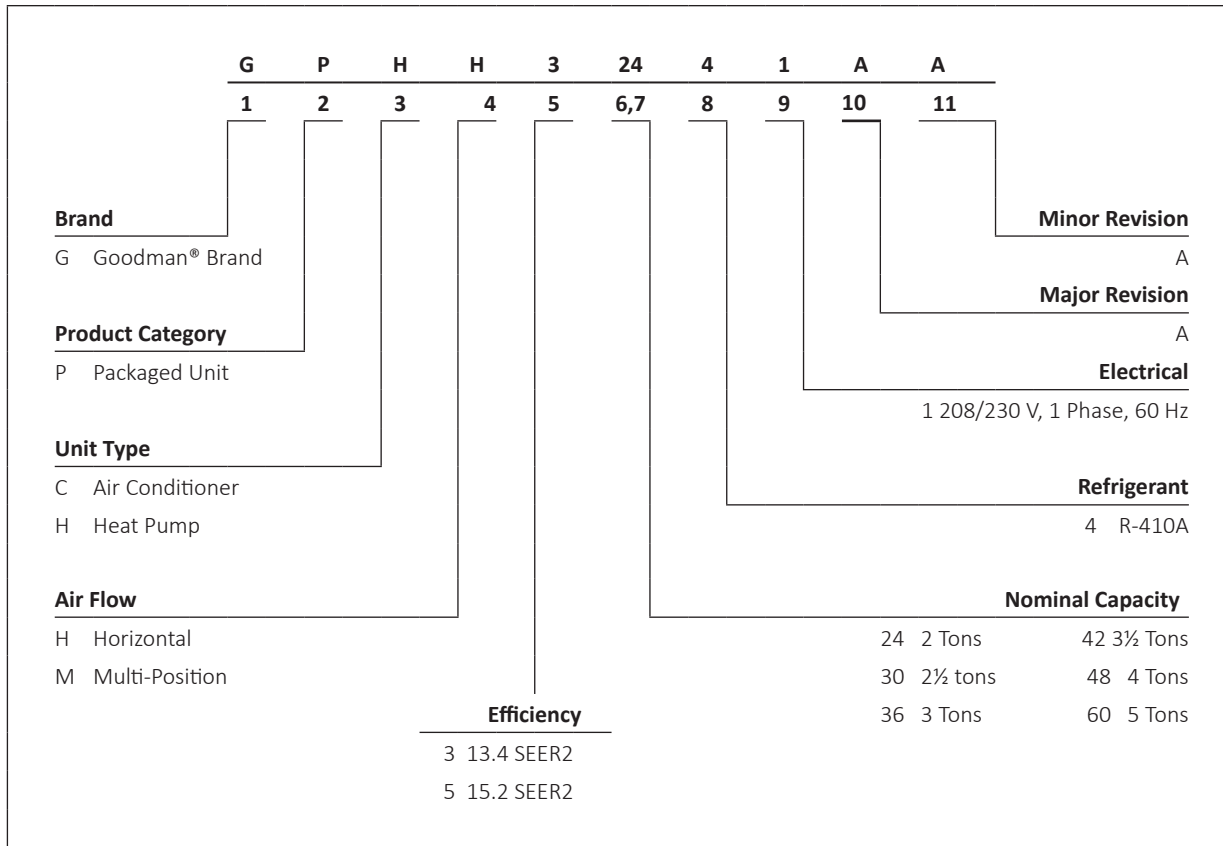

	GP HH32441**	GP HH33041**	GP HH33641**	GP HH34241**	GP HH34841**	GP HH36041**
COOLING CAPACITY						
Total BTU/h	23,400	27,800	35,200	39,000	46,000	57,000
Sensible BTU/h	18,088	21,934	27,632	30,615	36,616	41,838
SEER2/EER2	13.4 / 10.6	13.4 / 10.6	13.4 / 10.6	13.4 / 10.6	13.4 / 10.6	13.4 / 10.6
AHRI Numbers	208842404	208842405	208842406	208842407	208842408	208842409
HEATING CAPACITY						
BTU/h (47°F)	22,800	27,600	32,200	37,200	43,500	54,500
C.O.P. (47°F)	3.60	3.54	3.70	3.68	3.62	3.58
BTU/h (17°F)	13,000	15,400	19,400	21,600	24,800	32,200
C.O.P. (17°F)	2.28	2.38	2.34	2.42	2.24	2.36
HSPF2	6.70	6.70	6.70	6.70	6.70	6.70
EVAPORATOR MOTOR						
Type	ECM	ECM	ECM	ECM	ECM	ECM
Wheel (D x W)	10 x 8	10 x 8	10 x 8	10 x 8	10 x 8	11 x 8
Cooling CFM ³	875	1,050	1,200	1,300	1,570	1,700
Fan-Only CFM	685	581	958	1,061	1,094	1,202
No. of Speeds	5	5	5	5	5	5
Horsepower - RPM	1/2 - 1050	1/2 - 1050	1/2 - 1050	1/2 - 1050	3/4 - 1050	3/4 - 1050
EVAPORATOR COIL						
Face Area (ft ²)	5.26	5.26	6.23	6.23	6.23	7.01
Rows Deep	3	3	3	4	4	4
Fins per Inch	14	14	14	14	14	14
Metering Device Type	Piston	Piston	Piston	Piston	Piston	Piston
Drain Size (NPT)	3/4"	3/4"	3/4"	3/4"	3/4"	3/4"
Refrigerant Charge (oz.)	105	105	116	132	170	173
CONDENSER FAN						
Horsepower - RPM	1/6 - 810	1/6 - 810	1/4 - 830	1/4 - 1075	1/4 - 1075	1/4 - 1075
Fan Diameter	22	22	22	22	22	22
# Fan Blades	3	3	4	4	4	4
CONDENSER COIL						
Face Area (ft ²)	13.37	13.37	17.02	17.02	17.02	18.85
Rows Deep	1	1	1	1	2	2
Fins per Inch	24	24	24	24	16	20
Metering Device Type	Piston	Piston	Piston	Piston	Piston	Piston
COMPRESSOR						
Quantity	1	1	1	1	1	1
Type	Scroll	Scroll	Scroll	Scroll	Scroll	Scroll
Stage	Single	Single	Single	Single	Single	Single
SOUND POWER						
dBA	76	76	78	78	80	80
ELECTRICAL DATA						
Compressor RLA/LRA	12.8 / 58.3	14.1 / 73	16.7 / 79	16.7 / 109	19.9 / 109	26.4 / 134
Voltage/Phase (60 Hz)	208-230 / 1	208-230 / 1	208-230 / 1	208-230 / 1	208-230 / 1	208-230 / 1
Indoor Blower FLA	3.8	3.8	3.8	3.8	5.4	5.4
Outdoor Fan FLA	0.95	0.95	1.3	1.4	1.4	1.4
M.C.A. ¹	20.8	22.4	26	26.1	31.7	39.8
M.O.P. ²	30	35	40	40	50	60
OPERATING WEIGHT (LBS)	315	315	375	375	375	400
SHIP WEIGHT (LBS)	324	324	387	387	387	412

¹ Wire size should be determined in accordance with National Electrical Codes. Extensive wire runs will require larger wire sizes.

² Must use time-delay fuses or HACR-type circuit breakers of the same size as noted.

³ Factory

Note: Always check the S&R plate for electrical data on the unit being installed.

		OUTDOOR AMBIENT TEMPERATURE																			
		85					95					105					115				
		ENTERING INDOOR WET BULB TEMPERATURE																			
IDB	AIRFLOW	59	63	67	71	59	63	67	71	59	63	67	71	59	63	67	71	59	63	67	71
80	Mb/h	40.4	41.0	42.2	44.0	40.1	40.6	41.8	43.6	39.0	39.6	40.8	42.6	37.3	37.8	39.0	40.8	35.1	35.6	36.8	38.6
	S/T	1.00	0.87	0.73	0.6	1.00	0.88	0.74	0.6	1.00	0.91	0.77	0.6	1.00	1.00	0.79	0.6	1.00	1.00	0.81	0.7
	ΔT	26.54	24.72	21.34	17.8	26.49	24.67	21.29	17.8	26.75	24.93	21.54	18.0	26.47	24.66	21.27	17.8	26.23	24.41	21.02	17.5
	KW	2.64	2.63	2.63	2.7	2.96	2.96	2.95	3.0	3.32	3.32	3.32	3.3	3.72	3.71	3.71	3.7	4.15	4.15	4.15	4.2
	Amps	10.57	10.56	10.54	10.6	12.06	12.05	12.02	12.1	13.72	13.71	13.68	13.8	15.51	15.50	15.48	15.6	17.52	17.51	17.48	17.6
	Hi/PR	282	283	285	289.6	326	327	329	333.5	372	373	375	379.6	421	422	424	429.1	475	476	478	482.6
	Lo/PR	129	131	134	139.4	137	138	142	147.1	144	145	148	153.9	149	151	154	159.6	155	157	160	165.2
	Mb/h	40.8	41.4	42.5	44.4	40.4	41.0	42.2	44.0	39.4	40.0	41.2	43.0	37.6	38.2	39.4	41.2	35.4	36.0	37.2	39.0
	S/T	1.00	0.90	0.76	0.6	1.00	0.90	0.76	0.6	1.00	1.00	0.79	0.6	1.00	1.00	0.81	0.7	1.00	1.00	0.83	0.7
	ΔT	25.96	24.14	20.75	17.2	25.91	24.09	20.70	17.2	26.16	24.35	20.96	17.4	25.89	24.07	20.68	17.2	25.65	23.83	20.44	16.9
KW	2.65	2.64	2.64	2.7	2.97	2.97	2.96	3.0	3.33	3.33	3.33	3.4	3.73	3.72	3.72	3.7	4.16	4.16	4.16	4.2	
Amps	10.61	10.60	10.58	10.7	12.10	12.09	12.06	12.2	13.76	13.75	13.72	13.8	15.55	15.54	15.52	15.6	17.56	17.55	17.52	17.6	
Hi/PR	283	284	286	291.0	327	328	330	334.9	373	374	376	381.0	423	424	426	430.5	476	477	479	484.0	
Lo/PR	130	132	135	140.7	138	140	143	148.4	145	146	150	155.1	151	152	155	160.8	156	158	161	166.4	
1575	Mb/h	41.6	42.1	43.3	45.1	41.2	41.8	43.0	44.8	40.2	40.7	41.9	43.7	38.4	38.9	40.1	41.9	36.2	36.8	38.0	39.8
	S/T	1.00	0.92	0.78	0.6	1.00	0.92	0.78	0.6	1.00	1.00	0.81	0.7	1.00	1.00	0.83	0.7	1.00	1.00	0.85	0.7
	ΔT	25.04	23.23	19.84	16.3	24.99	23.18	19.79	16.3	25.25	23.43	20.04	16.5	24.97	23.16	19.77	16.3	24.73	22.92	19.53	16.0
	KW	2.66	2.66	2.65	2.7	2.98	2.98	2.98	3.0	3.35	3.34	3.34	3.4	3.74	3.74	3.73	3.8	4.18	4.18	4.17	4.2
	Amps	10.68	10.67	10.64	10.8	12.16	12.15	12.13	12.2	13.82	13.81	13.79	13.9	15.62	15.61	15.58	15.7	17.62	17.61	17.59	17.7
	Hi/PR	285	287	289	293.5	329	331	333	337.4	375	377	379	383.5	425	426	428	433.0	478	480	482	486.5
	Lo/PR	133	134	138	143.1	141	142	145	150.8	147	149	152	157.5	153	155	158	163.2	159	160	163	168.8
	Mb/h	41.1	41.7	42.8	44.7	40.7	41.3	42.5	44.3	39.7	40.3	41.5	43.3	37.9	38.5	39.7	41.5	35.7	36.3	37.5	39.3
	S/T	1.00	0.98	0.84	0.7	1.00	1.00	0.84	0.7	1.00	1.00	0.87	0.7	1.00	1.00	0.89	0.7	1.00	1.00	1.00	0.8
	ΔT	30.10	28.29	24.90	21.4	30.05	28.24	24.85	21.3	30.31	28.49	25.10	21.6	30.04	28.22	24.83	21.3	29.79	27.98	24.59	21.1
KW	2.64	2.64	2.64	2.7	2.97	2.97	2.96	3.0	3.33	3.33	3.32	3.3	3.72	3.72	3.71	3.7	4.16	4.16	4.15	4.2	
Amps	10.60	10.59	10.56	10.7	12.09	12.08	12.05	12.2	13.75	13.73	13.71	13.8	15.54	15.53	15.50	15.6	17.55	17.54	17.51	17.6	
Hi/PR	283	284	286	290.9	327	328	330	334.8	373	374	376	380.9	422	424	426	430.4	476	477	479	483.9	
Lo/PR	131	133	136	141.3	139	140	144	149.0	146	147	150	155.8	151	153	156	161.5	157	158	162	167.1	
85	Mb/h	41.5	42.0	43.2	45.0	41.1	41.7	42.9	44.7	40.1	40.6	41.8	43.6	38.3	38.9	40.0	41.9	36.1	36.7	37.9	39.7
	S/T	1.00	1.00	0.86	0.7	1.00	1.00	0.87	0.7	1.00	1.00	0.89	0.7	1.00	1.00	0.91	0.8	1.00	1.00	1.00	0.8
	ΔT	29.52	27.70	24.32	20.8	29.47	27.65	24.27	20.8	29.73	27.91	24.52	21.0	29.45	27.64	24.25	20.7	29.21	27.39	24.00	20.5
	KW	2.65	2.65	2.64	2.7	2.98	2.97	2.97	3.0	3.34	3.34	3.33	3.4	3.73	3.73	3.72	3.7	4.17	4.17	4.16	4.2
	Amps	10.64	10.63	10.61	10.7	12.13	12.12	12.09	12.2	13.79	13.78	13.75	13.9	15.58	15.57	15.55	15.7	17.59	17.58	17.55	17.7
	Hi/PR	284	285	287	292.3	328	329	331	336.2	374	375	377	382.3	424	425	427	431.8	477	478	480	485.3
	Lo/PR	132	134	137	142.6	140	142	145	150.3	147	148	152	157.0	153	154	157	162.7	158	160	163	168.3
	Mb/h	42.2	42.8	44.0	45.8	41.9	42.4	43.6	45.4	40.8	41.4	42.6	44.4	39.1	39.6	40.8	42.6	36.9	37.4	38.6	40.4
	S/T	1.00	1.00	0.88	0.7	1.00	1.00	0.89	0.7	1.00	1.00	0.92	0.8	1.00	1.00	1.00	0.8	1.00	1.00	1.00	0.8
	ΔT	28.61	26.79	23.40	19.9	28.56	26.74	23.35	19.8	28.81	27.00	23.61	20.1	28.54	26.72	23.33	19.8	28.29	26.48	23.09	19.6
KW	2.67	2.66	2.66	2.7	2.99	2.99	2.98	3.0	3.35	3.35	3.35	3.4	3.75	3.74	3.74	3.8	4.18	4.18	4.18	4.2	
Amps	10.71	10.69	10.67	10.8	12.19	12.18	12.16	12.3	13.85	13.84	13.81	13.9	15.65	15.63	15.61	15.7	17.65	17.64	17.62	17.7	
Hi/PR	287	288	290	294.8	331	332	334	338.7	377	378	380	384.8	426	428	429	434.3	480	481	483	487.8	
Lo/PR	135	136	140	145.0	142	144	147	152.7	149	151	154	159.4	155	157	160	165.1	161	162	165	170.7	

IDB: Entering Indoor Dry Bulb Temperature

High and low pressures are measured at the liquid and suction service valves.

Design Subcooling, 5-7 °F @ the liquid access fitting connection AHRI 95 test conditions. Design Superheat 15-18°F @ the compressor suction access fitting connection.

KW = Total system power
Amps = outdoor unit amps (comp.+fan)
Shaded area reflects ACCA (TVA) conditions.

IDB		OUTDOOR AMBIENT TEMPERATURE																										
		65					75					85					95				105				115			
		59	63	67	71	75	59	63	67	71	75	59	63	67	71	75	59	63	67	71	59	63	67	71	59	63	67	71
80	1500	Mbh	58.4	59.2	60.9	63.6	57.8	58.7	60.4	63.0	56.3	57.2	58.9	61.5	53.7	54.5	56.3	58.9	50.5	51.4	53.1	55.7	47.6	48.5	50.2	52.8		
		S/T	0.84	0.76	0.63	0.5	1.00	0.77	0.64	0.5	1.00	0.79	0.66	0.5	1.00	0.81	0.68	0.5	1.00	1.00	1.00	0.70	0.6	1.00	1.00	0.75	0.6	
		ΔT	29.67	27.72	24.07	20.3	29.62	27.66	24.02	20.2	29.89	27.94	24.29	20.5	29.60	27.64	24.00	20.2	29.34	27.38	23.74	20.0	30.56	28.61	24.96	21.2		
		KW	3.78	3.78	3.77	3.8	4.27	4.27	4.26	4.3	4.82	4.81	4.81	4.8	5.41	5.41	5.40	5.4	6.07	6.07	6.06	6.1	6.85	6.84	6.84	6.9		
		Amps	15.05	15.03	14.99	15.2	17.29	17.28	17.24	17.4	19.80	19.78	19.74	19.9	22.51	22.49	22.45	22.6	25.54	25.52	25.48	25.7	29.09	29.07	29.03	29.2		
	Hi/PR	277	278	280	284.9	321	322	324	328.5	366	367	369	374.1	415	417	418	423.3	468	469	471	476.2	525	526	528	532.8			
	Lo/PR	121	123	126	130.8	128	130	133	138.1	135	136	139	144.5	140	142	145	149.9	146	147	150	155.3	152	154	157	161.9			
	1700	Mbh	59.1	59.9	61.6	64.3	58.6	59.4	61.1	63.8	57.1	57.9	59.6	62.3	54.4	55.3	57.0	59.6	51.3	52.1	53.8	56.5	48.4	49.2	50.9	53.6		
		S/T	1.00	0.82	0.69	0.5	1.00	0.82	0.69	0.6	1.00	0.85	0.72	0.6	1.00	0.87	0.73	0.6	1.00	1.00	1.00	0.76	0.6	1.00	1.00	0.81	0.7	
		ΔT	28.57	26.61	22.97	19.2	28.51	26.56	22.91	19.1	28.79	26.84	23.19	19.4	28.49	26.54	22.89	19.1	28.23	26.28	22.63	18.9	29.46	27.50	23.85	20.1		
KW		3.80	3.80	3.79	3.8	4.29	4.29	4.28	4.3	4.84	4.84	4.83	4.9	5.43	5.43	5.42	5.5	6.10	6.09	6.08	6.1	6.87	6.87	6.86	6.9			
Amps		15.16	15.14	15.10	15.3	17.40	17.39	17.35	17.5	19.91	19.89	19.85	20.0	22.62	22.60	22.56	22.7	25.64	25.63	25.59	25.8	29.20	29.18	29.14	29.3			
Hi/PR	279	280	282	287.1	323	324	326	330.7	368	370	372	376.3	418	419	421	425.5	470	472	474	478.4	527	528	530	535.0				
Lo/PR	123	124	127	132.4	130	132	135	139.8	136	138	141	146.2	142	144	147	151.6	147	149	152	156.9	154	155	158	163.6				
85	1500	Mbh	59.3	60.2	61.9	64.5	58.8	59.6	61.4	64.0	57.3	58.1	59.9	62.5	54.7	55.5	57.3	59.9	51.5	52.3	54.1	56.7	48.6	49.4	51.2	53.8		
		S/T	1.00	0.86	0.73	0.6	1.00	0.87	0.74	0.6	1.00	0.88	0.75	0.6	1.00	0.90	0.77	0.6	1.00	1.00	1.00	0.79	0.6	1.00	1.00	0.84	0.7	
		ΔT	33.51	31.55	27.91	24.1	33.45	31.50	27.85	24.1	33.73	31.78	28.13	24.3	33.43	31.48	27.83	24.1	33.17	31.22	27.57	23.8	34.40	32.44	28.79	25.0		
		KW	3.79	3.79	3.78	3.8	4.28	4.28	4.27	4.3	4.83	4.82	4.82	4.9	5.42	5.42	5.41	5.4	6.08	6.08	6.07	6.1	6.86	6.85	6.84	6.9		
		Amps	15.09	15.08	15.04	15.2	17.34	17.32	17.28	17.5	19.84	19.82	19.79	20.0	22.55	22.53	22.50	22.7	25.58	25.56	25.52	25.7	29.13	29.11	29.08	29.2		
	Hi/PR	278	279	281	286.2	322	323	325	329.8	367	369	371	375.4	417	418	420	424.6	470	471	473	477.5	526	527	529	534.1			
	Lo/PR	123	124	127	132.6	130	132	135	139.9	137	138	141	146.3	142	144	147	151.7	147	149	152	157.1	154	156	159	163.7			
	1700	Mbh	60.1	60.9	62.6	65.3	59.5	60.4	62.1	64.7	58.0	58.8	60.6	63.2	55.4	56.2	58.0	60.6	52.2	53.1	54.8	57.4	49.3	50.2	51.9	54.5		
		S/T	1.00	0.91	0.78	0.6	1.00	0.92	0.79	0.7	1.00	0.93	0.81	0.7	1.00	0.95	0.83	0.7	1.00	1.00	1.00	0.85	0.7	1.00	1.00	0.90	0.8	
		ΔT	32.40	30.45	26.80	23.0	32.35	30.40	26.75	23.0	32.63	30.67	27.02	23.2	32.33	30.38	26.73	22.9	32.07	30.12	26.47	22.7	33.29	31.34	27.69	23.9		
KW		3.81	3.81	3.80	3.8	4.30	4.30	4.29	4.3	4.85	4.85	4.84	4.9	5.44	5.44	5.43	5.5	6.10	6.10	6.09	6.1	6.88	6.88	6.87	6.9			
Amps		15.20	15.18	15.15	15.3	17.45	17.43	17.39	17.6	19.95	19.93	19.89	20.1	22.66	22.64	22.60	22.8	25.69	25.67	25.63	25.8	29.24	29.22	29.18	29.4			
Hi/PR	280	282	284	288.4	324	325	327	332.0	370	371	373	377.6	419	420	422	426.8	472	473	475	479.7	528	530	531	536.3				
Lo/PR	125	126	129	134.2	132	133	136	141.6	138	140	143	148.0	144	146	149	153.4	149	151	154	158.7	156	158	160	165.4				
1900	Mbh	60.9	61.7	63.5	66.1	60.4	61.2	63.0	65.6	58.9	59.7	61.4	64.1	56.3	57.1	58.8	61.5	53.1	53.9	55.6	58.3	50.2	51.0	52.7	55.4			
	S/T	1.00	0.95	0.81	0.7	1.00	0.95	0.82	0.7	1.00	1.00	0.84	0.7	1.00	1.00	0.86	0.7	1.00	1.00	1.00	0.89	0.7	1.00	1.00	0.90	0.8		
	ΔT	31.46	29.51	25.86	22.1	31.41	29.46	25.81	22.0	31.69	29.73	26.08	22.3	31.39	29.44	25.79	22.0	31.13	29.18	25.53	21.7	32.35	30.40	26.75	23.0			
	KW	3.83	3.83	3.82	3.9	4.32	4.32	4.31	4.3	4.87	4.87	4.86	4.9	5.46	5.46	5.45	5.5	6.12	6.12	6.11	6.2	6.90	6.90	6.89	6.9			
	Amps	15.29	15.28	15.24	15.4	17.54	17.52	17.48	17.7	20.04	20.02	19.99	20.2	22.75	22.73	22.70	22.9	25.78	25.76	25.72	25.9	29.33	29.31	29.28	29.4			
Hi/PR	283	284	286	290.6	326	327	329	334.1	372	373	375	379.8	421	422	424	428.9	474	475	477	481.9	530	532	534	538.4				
Lo/PR	126	128	131	136.1	134	135	138	143.4	140	142	145	149.8	146	148	150	155.2	151	152	155	160.6	158	159	162	167.2				

KW = Total system power
Amps = outdoor unit amps (comp.+fan)
Shaded area reflects ACCA (TVA) conditions.

IDB: Entering Indoor Dry Bulb Temperature
High and low pressures are measured at the liquid and suction service valves.
Design Subcooling, 5-7°F @ the liquid access fitting connection AHRI 95 test conditions. Design Superheat 15-18°F @ the compressor suction access fitting connection.

EXPANDED HEATING DATA

GP HH32441

	OUTDOOR AMBIENT TEMPERATURE																
	65	60	55	50	47	45	40	35	30	25	20	17	15	10	5	-5	
MBh	29.20	27.41	25.65	23.92	22.80	21.99	19.95	18.03	16.45	15.29	14.45	14.00	13.41	11.95	10.48	9.01	7.55
T/R	29.72	28.16	26.61	25.06	24.13	23.29	21.11	19.07	17.41	16.18	15.29	14.81	14.19	12.64	11.09	9.54	7.98
KW	1.95	1.93	1.90	1.88	1.86	1.85	1.83	1.80	1.78	1.75	1.72	1.71	1.70	1.67	1.65	1.62	1.60
AMPS	7.10	6.99	6.88	6.77	6.70	6.66	6.55	6.44	6.33	6.22	6.11	6.04	6.00	5.89	5.78	5.67	5.56
COP	4.38	4.17	3.95	3.74	3.59	3.48	3.20	2.93	2.72	2.56	2.46	2.40	2.31	2.09	1.86	1.63	1.38
Hi PR	388.26	375.63	363.01	350.38	342.80	337.75	325.12	312.49	299.86	287.23	274.60	267.03	261.98	249.35	236.72	224.09	211.46
LO PR	136.59	128.10	119.60	111.10	106.00	102.60	94.10	85.60	77.11	68.61	60.11	55.01	51.61	43.11	34.61	26.12	17.62

GP HH33041

	OUTDOOR AMBIENT TEMPERATURE																
	65	60	55	50	47	45	40	35	30	25	20	17	15	10	5	-5	
MBh	36.32	33.87	31.47	29.11	27.60	26.46	23.59	20.97	18.83	17.24	16.04	15.40	14.59	12.55	10.52	8.49	6.45
T/R	30.80	29.00	27.21	25.42	24.34	23.33	20.80	18.49	16.61	15.20	14.15	13.58	12.86	11.07	9.28	7.48	5.69
KW	2.52	2.45	2.39	2.32	2.29	2.26	2.19	2.13	2.06	2.00	1.94	1.90	1.87	1.81	1.74	1.68	1.61
AMPS	9.28	9.00	8.72	8.44	8.27	8.16	7.87	7.59	7.31	7.03	6.75	6.58	6.47	6.18	5.90	5.62	5.34
COP	4.23	4.05	3.86	3.67	3.54	3.43	3.15	2.89	2.67	2.53	2.43	2.38	2.29	2.04	1.77	1.48	1.17
Hi PR	403.21	390.10	376.98	363.87	356.00	350.75	337.64	324.52	311.41	298.29	285.18	277.31	272.06	258.95	245.83	232.72	219.60
LO PR	128.86	120.84	112.83	104.81	100.00	96.79	88.78	80.76	72.74	64.72	56.71	51.90	48.69	40.67	32.66	24.64	16.62

GP HH33641

	OUTDOOR AMBIENT TEMPERATURE																
	65	60	55	50	47	45	40	35	30	25	20	17	15	10	5	-5	
MBh	42.77	39.84	37.21	34.20	32.20	30.57	26.58	23.04	20.17	17.99	16.30	15.40	14.28	11.48	8.68	5.88	3.08
T/R	32.63	30.46	28.30	26.14	24.85	23.58	20.51	17.78	15.57	13.88	12.58	11.88	11.02	8.86	6.70	4.54	2.38
KW	2.92	2.82	2.72	2.61	2.55	2.51	2.41	2.30	2.20	2.09	1.99	1.93	1.89	1.78	1.68	1.58	1.47
AMPS	10.81	10.36	9.91	9.46	9.19	9.01	8.55	8.10	7.65	7.20	6.75	6.48	6.30	5.85	5.40	4.95	4.50
COP	4.29	4.14	4.01	3.84	3.70	3.57	3.24	2.93	2.69	2.52	2.40	2.34	2.22	1.89	1.51	1.09	0.61
Hi PR	352.81	341.34	329.86	318.39	311.50	306.91	295.43	283.96	272.48	261.01	249.53	242.65	238.06	226.58	215.10	203.63	192.15
LO PR	131.44	123.26	115.08	106.91	102.00	98.73	90.55	82.37	74.20	66.02	57.84	52.93	49.66	41.49	33.31	25.13	16.95

Calculations are based on nominal CFM and 70 °F indoor dry bulb.

Note: Shaded area is AHRI Rating Conditions at 47°F outdoor ambient temperature

Amps = Outdoor unit amps (comp.+fan)

kW = Total system power

GP HH34241

	OUTDOOR AMBIENT TEMPERATURE																
	65	60	55	50	47	45	40	35	30	25	20	17	15	10	5	-5	
MBh	48.42	45.28	42.19	39.15	37.20	35.76	32.10	28.72	25.97	23.93	22.41	21.60	20.56	17.96	15.36	12.76	10.16
T/R	33.16	31.31	29.46	27.61	26.50	25.47	22.86	20.46	18.50	17.04	15.96	15.38	14.64	12.79	10.94	9.09	7.24
KW	3.17	3.11	3.06	3.00	2.96	2.94	2.88	2.82	2.77	2.71	2.65	2.62	2.59	2.54	2.48	2.42	2.36
AMPS	11.72	11.47	11.22	10.97	10.82	10.72	10.47	10.22	9.96	9.71	9.46	9.31	9.21	8.96	8.71	8.46	8.21
COP	4.48	4.26	4.05	3.83	3.68	3.57	3.26	2.98	2.75	2.59	2.48	2.42	2.32	2.08	1.82	1.55	1.26
Hi PR	364.70	352.84	340.98	329.12	322.00	317.26	305.39	293.53	281.67	269.81	257.94	250.83	246.08	234.22	222.36	210.49	198.63
LO PR	132.73	124.47	116.21	107.95	103.00	99.70	91.44	83.18	74.92	66.67	58.41	53.45	50.15	41.89	33.63	25.38	17.12

GP HH34841

	OUTDOOR AMBIENT TEMPERATURE																
	65	60	55	50	47	45	40	35	30	25	20	17	15	10	5	-5	
MBh	56.91	53.15	49.46	45.82	43.50	41.76	37.37	33.34	30.05	27.60	25.78	24.80	23.55	20.44	17.32	14.20	11.09
T/R	31.67	29.87	28.06	26.26	25.18	24.17	21.62	19.29	17.39	15.97	14.92	14.35	13.63	11.83	10.02	8.22	6.41
KW	3.69	3.64	3.60	3.55	3.52	3.50	3.46	3.41	3.36	3.32	3.27	3.24	3.23	3.18	3.13	3.09	3.04
AMPS	13.50	13.30	13.09	12.89	12.77	12.69	12.49	12.29	12.09	11.89	11.69	11.57	11.49	11.29	11.09	10.89	10.69
COP	4.52	4.28	4.03	3.78	3.62	3.49	3.17	2.86	2.62	2.44	2.31	2.24	2.14	1.88	1.62	1.35	1.07
Hi PR	368.67	356.68	344.69	332.69	325.50	320.70	308.71	296.72	284.73	272.74	260.75	253.55	248.75	236.76	224.77	212.78	200.79
LO PR	133.63	125.32	117.00	108.69	103.70	100.37	92.06	83.75	75.43	67.12	58.81	53.82	50.49	42.18	33.86	25.55	17.24

GP HH36041

	OUTDOOR AMBIENT TEMPERATURE																
	65	60	55	50	47	45	40	35	30	25	20	17	15	10	5	-5	
MBh	70.60	66.09	61.66	57.30	54.50	52.45	47.23	42.39	38.44	35.51	33.36	32.20	30.71	27.00	23.28	19.56	15.85
T/R	36.97	34.95	32.93	30.90	29.69	28.57	25.72	23.09	20.94	19.34	18.17	17.54	16.73	14.70	12.68	10.65	8.63
KW	4.74	4.66	4.59	4.51	4.46	4.43	4.35	4.28	4.20	4.12	4.05	4.00	3.97	3.89	3.81	3.74	3.66
AMPS	17.91	17.57	17.24	16.90	16.70	16.57	16.23	15.90	15.56	15.23	14.89	14.69	14.55	14.22	13.88	13.55	13.21
COP	4.37	4.15	3.94	3.73	3.58	3.47	3.18	2.91	2.68	2.52	2.42	2.36	2.27	2.03	1.79	1.53	1.27
Hi PR	395.29	382.43	369.57	356.71	349.00	343.86	331.00	318.14	305.29	292.43	279.57	271.86	266.71	253.86	241.00	228.14	215.29
LO PR	127.57	119.64	111.70	103.76	99.00	95.83	87.89	79.95	72.01	64.08	56.14	51.38	48.20	40.27	32.33	24.39	16.45

Calculations are based on nominal CFM and 70 °F indoor dry bulb.

Amps = Outdoor unit amps (comp.+fan)

Note: Shaded area is AHRI Rating Conditions at 47°F outdoor ambient temperature

kW = Total system power

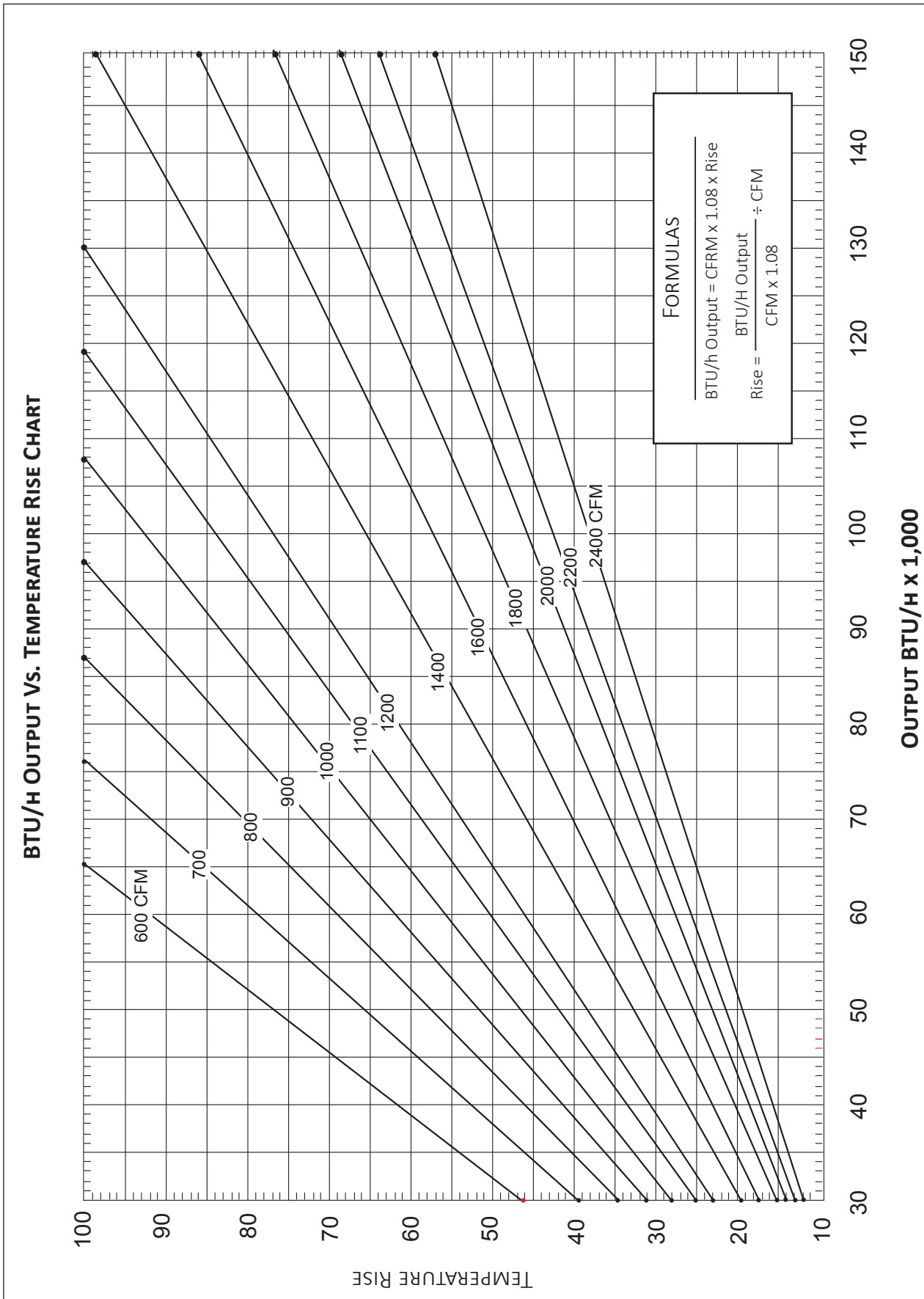

MODEL	SPEED*	VOLTS		E.S.P. (IN. OF H ₂ O)							
				0.10	0.20	0.30	0.40	0.50	0.60	0.70	0.80
GPHH32441	T1	230	CFM Watts	922 74	873 85	823 96	774 107	724 118	675 129	626 140	576 151
	T2,T3	230	CFM Watts	1,172 135	1,121 145	1,068 155	1,012 164	953 175	892 186	832 184	762 203
	T4, T5	230	CFM Watts	1,231 168	1,179 180	1,127 193	1,074 205	1,022 218	969 230	917 243	865 255
GPHH33041	T1	230	CFM Watts	864 72	808 82	757 91	695 103	636 107	567 115	494 123	437 131
	T2,T3	230	CFM Watts	1,323 179	1,270 190	1,220 199	1,171 209	1,119 219	1,060 230	997 240	945 248
	T4, T5	230	CFM Watts	1,404 235	1,362 246	1,321 257	1,271 272	1,238 284	1,191 289	1,150 300	1,105 309
GPHH33641	T1	230	CFM Watts	1,161 139	1,113 150	1,076 163	1,034 172	994 184	949 194	889 207	837 218
	T2,T3	230	CFM Watts	1,379 216	1,343 229	1,305 241	1,265 254	1,226 264	1,190 276	1,148 285	1,108 296
	T4, T5	230	CFM Watts	1,542 291	1,502 301	1,462 314	1,427 327	1,392 339	1,352 349	1,316 359	1,280 371
GPHH34241	T1	230	CFM Watts	1,271 168	1,214 177	1,167 188	1,127 200	1,095 214	1,052 224	1,013 235	971 249
	T2,T3	230	CFM Watts	1,491 245	1,451 258	1,406 268	1,369 281	1,335 294	1,295 305	1,262 318	1,226 330
	T4, T5	230	CFM Watts	1,736 356	1,679 372	1,638 382	1,598 395	1,558 408	1,520 422	1,484 433	1,441 442
GPHH34841	T1	230	CFM Watts	1,337 179	1,297 190	1,218 203	1,155 210	1,118 225	1,088 243	1,022 249	989 268
	T2/T3	230	CFM Watts	1,758 394	1,715 406	1,674 418	1,637 430	1,596 443	1,557 455	1,518 466	1,474 474
	T4/T5	230	CFM Watts	2,002 498	1,935 521	1,885 516	1,827 534	1,767 551	1,732 567	1,669 571	1,618 574
GPHH36041	T1	230	CFM Watts	1,418 212	1,357 219	1,315 227	1,274 236	1,239 243	1,193 252	1,148 266	1,102 275
	T2,T3	230	CFM Watts	1,862 437	1,812 447	1,763 454	1,719 461	1,685 473	1,649 480	1,615 483	1,583 493
	T4, T5	230	CFM Watts	1,933 491	1,886 499	1,838 506	1,796 519	1,759 527	1,723 534	1,693 539	1,669 550

* Speed set at T2 at factory.

HEAT KIT ELECTRICAL DATA (BLOWER ONLY, HEAT MODE)

MODEL AND HEAT KIT USAGE	CIRCUIT #1		CIRCUIT #2		SINGLE-POINT KIT		ACTUAL KW / BTU@ 240V
	MCA ¹	MOD ²	MCA ¹	MOD ²	MCA ¹	MOP ²	
GPHH32441**	1.9	---	---	---	--	--	---
HKR-05*, HKR-05C*	21 / 25	25 / 25	---	---	46	50	4.75 / 16,200
HKR-08*, HKR-08C*	32 / 36	35 / 40	---	---	57	60	7 / 23,800
HKR-10*, HKR-10C*	43 / 49	45 / 50	---	---	70	80	9.5 / 32,400
GPHH33041**	2.3	---	---	---	--	--	---
HKR-05*, HKR-05C*	21 / 25	25 / 25	---	---	47	50	4.75 / 16,200
HKR-08*, HKR-08C*	32 / 36	35 / 40	---	---	59	60	7 / 23,800
HKR-10*, HKR-10C*	43 / 49	45 / 50	---	---	72	80	9.5 / 32,400
HKP-15C*	43 / 49	45 / 50	21 / 25	25 / 25	97	100	14.25 / 48,600
GPHH33641**	2.3	---	---	---	--	--	---
HKR-05*, HKR-05C*	21 / 25	25 / 25	---	---	50.7	60	4.75 / 16,200
HKR-08*, HKR-08C*	32 / 36	35 / 40	---	---	62.4	70	7 / 23,800
HKR-10*, HKR-10C*	43 / 49	45 / 50	---	---	75.5	80	9.5 / 32,400
HKP-15C*	43 / 49	45 / 50	21 / 25	25 / 25	100.2	110	14.25 / 48,600
GPHH34241**	3.6	---	---	---	--	--	---
HKP-05C*	21 / 25	25 / 25	---	---	52	60	4.75 / 16,200
HKR-08C*	32 / 36	35 / 40	---	---	64	70	7 / 23,800
HKP-10C*	43 / 49	45 / 50	---	---	77	80	9.5 / 32,400
HKP-15C*	43 / 49	45 / 50	21 / 25	25 / 25	102	110	14.25 / 48,600
HKP-20C	43 / 49	45 / 50	43 / 49	45 / 50	127	150	19.0 / 64,800
GPHH34841**	3.6	---	---	---	--	--	---
HKP-05C*	21 / 25	25 / 25	---	---	56	70	4.75 / 16,200
HKR-08C*	32 / 36	35 / 40	---	---	68	80	7 / 23,800
HKP-10C*	43 / 49	45 / 50	---	---	81	90	9.5 / 32,400
HKP-15C*	43 / 49	45 / 50	21 / 25	25 / 25	106	110	14.25 / 48,600
HKP-20C	43 / 49	45 / 50	43 / 49	45 / 50	131	150	19.0 / 64,800
GPHH36041**	7.5	---	---	---	--	--	---
HKP-05C*	21 / 25	25 / 25	---	---	65	80	4.75 / 16,200
HKR-08C*	32 / 36	35 / 40	---	---	76	90	7 / 23,800
HKP-10C*	43 / 49	45 / 50	---	---	89	100	9.5 / 32,400
HKP-15C*	43 / 49	45 / 50	21 / 25	25 / 25	114	125	14.25 / 48,600

HKP-20C

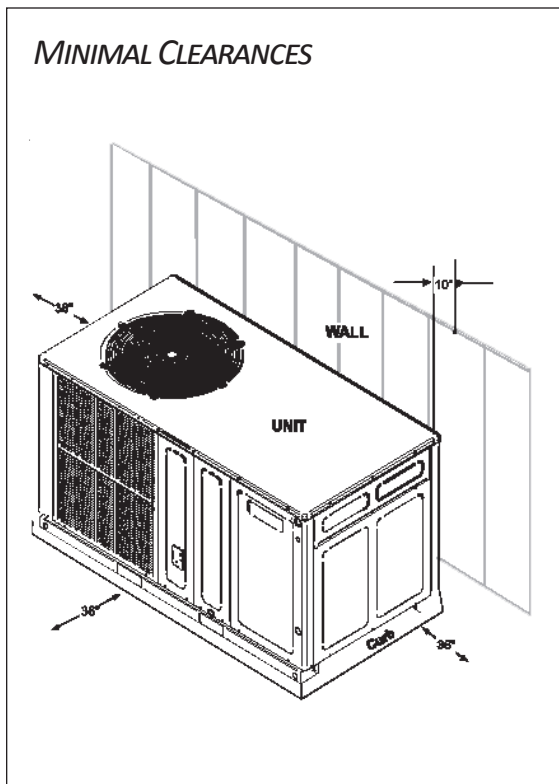
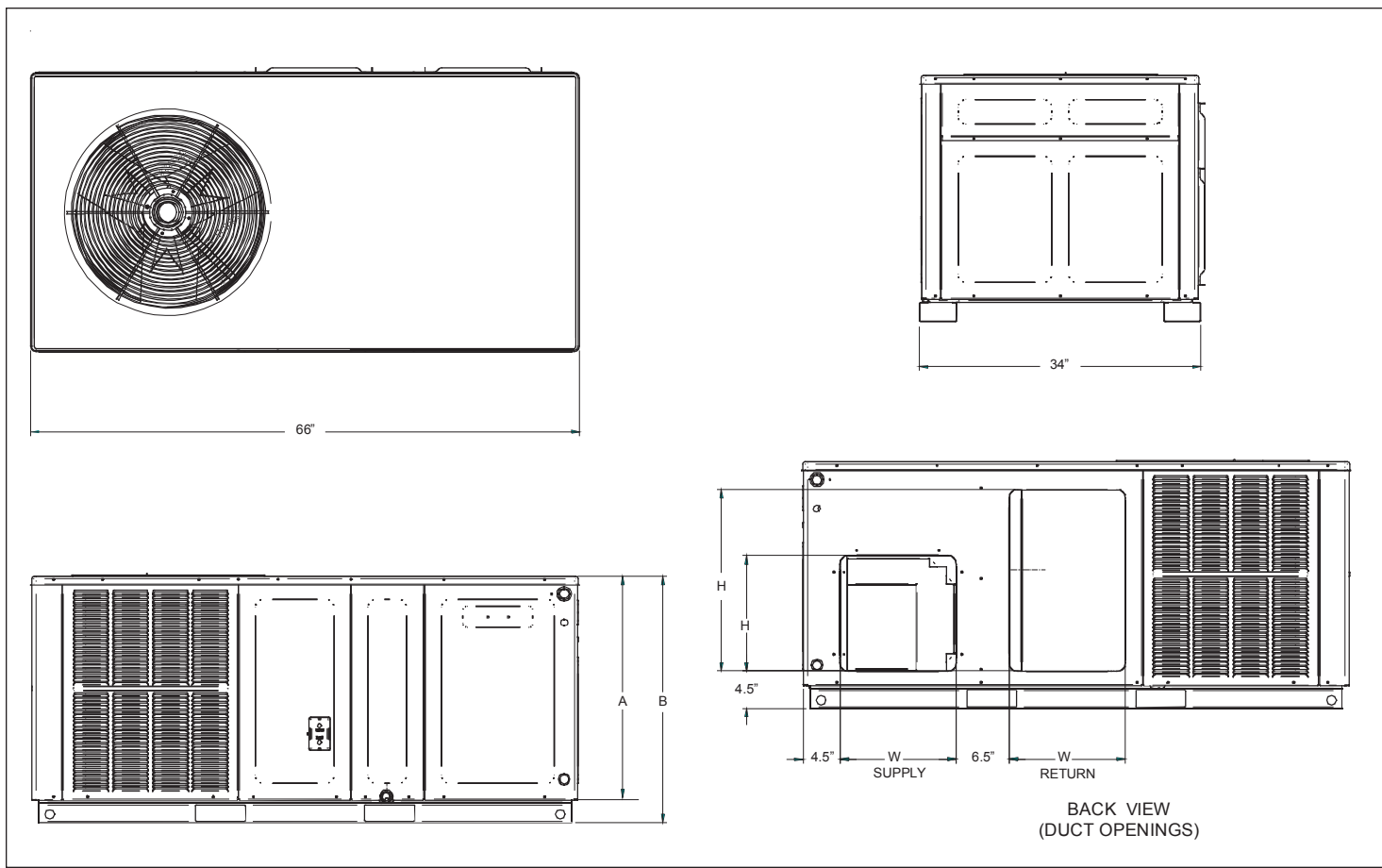

MODEL	UNIT DIMENSIONS				CHASSIS SIZE
	W	D	HEIGHT		
			A	B	
GPHH32441**	66	34	27½	30	Small
GPHH33041**	66	34	27½	30	Small
GPHH33641**	66	34	32½	35	Medium
GPHH34241**	66	34	32½	35	Medium
GPHH34841**	66	34	32½	35	Medium
GPHH36041**	66	34	36	38½	Large

MODEL	DUCT OPENINGS			
	SUPPLY		RETURN	
	W	H	W	H
GPHH32441**	14	14	14	22
GPHH33041**	14	14	14	22
GPHH33641**	14	14	14	24
GPHH34241**	14	14	14	24
GPHH34841**	14	14	14	24
GPHH36041**	14	14	14	24

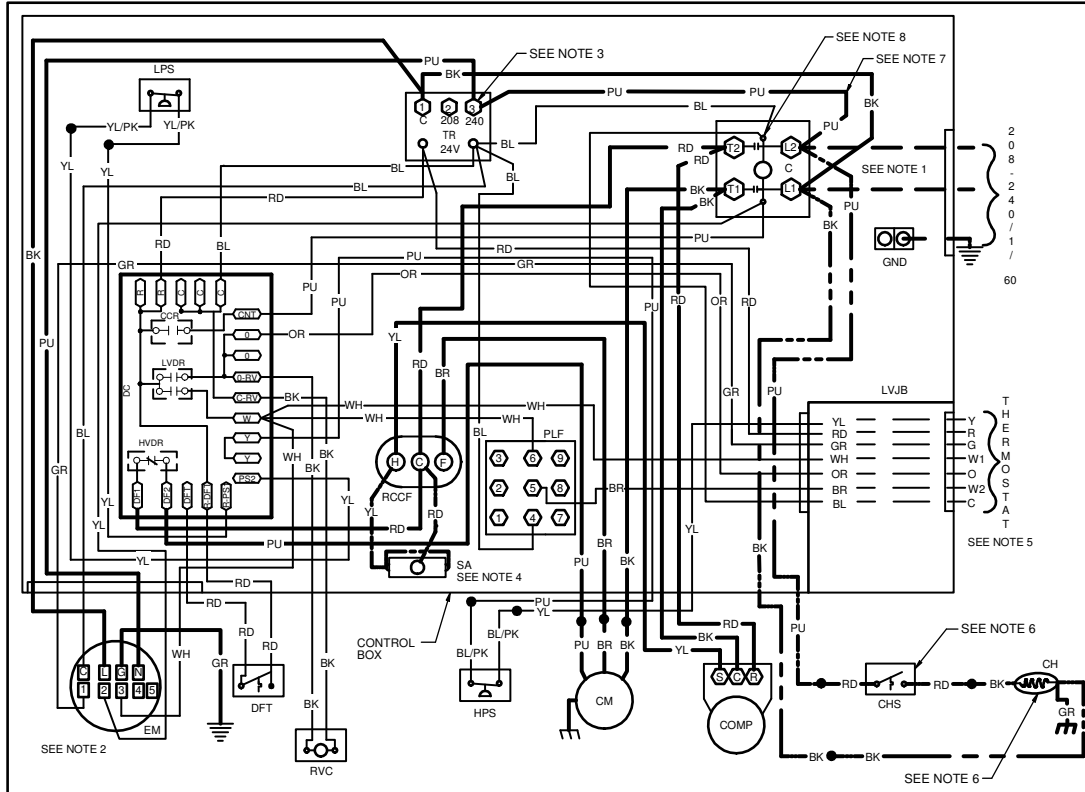

SEE NOTE 2

SEE NOTE 6

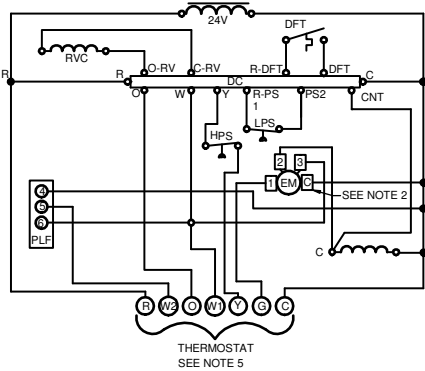
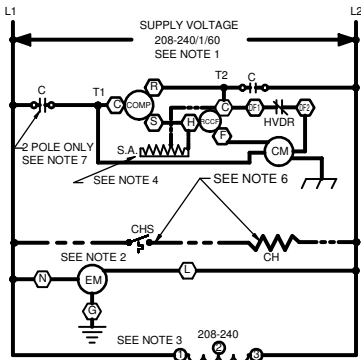

COMPONENT LEGEND

- C CONTACTOR
- CCR COMPRESSOR CONTACTOR RELAY
- CH CRANKCASE HEATER
- CHS CRANKCASE HEATER SWITCH
- CM CONDENSER MOTOR
- COMP COMPRESSOR
- DC DEFROST CONTROL
- DFT DEFROST THERMOSTAT
- EM EVAPORATOR MOTOR
- GND EQUIPMENT GROUND
- HVDR HIGH VOLTAGE DEFROST RELAY
- LPS LOW PRESSURE SWITCH
- LVDR LOW VOLTAGE DEFROST RELAY
- LVJB LOW VOLTAGE JUNCTION BOX
- PLF FEMALE PLUG / CONNECTOR
- RVC REVERSING VALVE COIL
- RCCF RUN CAPACITOR FOR COMPRESSOR AND FAN
- SA START ASSIST
- TR TRANSFORMER
- HPS HIGH PRESSURE SWITCH

FACTORY WIRING

- LINE VOLTAGE
- LOW VOLTAGE
- OPTIONAL HIGH VOLTAGE

FIELD WIRING

- - - HIGH VOLTAGE
- - - LOW VOLTAGE

WIRE CODE

- BK BLACK
- BL BLUE
- BR BROWN
- GR GREEN
- OR ORANGE
- PU PURPLE
- RD RED
- WH WHITE
- YL YELLOW

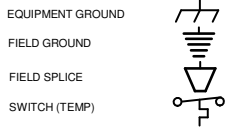
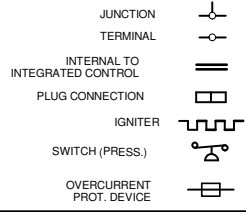

NOTES:

1. REPLACEMENT WIRE MUST BE SAME SIZE AND TYPE INSULATION AS ORIGINAL (AT LEAST 105°C) USE COPPER CONDUCTOR ONLY.
2. TO CHANGE EVAPORATOR MOTOR SPEED MOVE WHITE AND YELLOW LEADS FROM EM#2 AND #3 TO #4 AND #5. IF BOTH LEADS ARE ENERGIZED, THE HIGHER SPEED SETTING IS USED.
3. FOR 208 VOLT TRANSFORMER OPERATION MOVE PURPLE WIRES FROM TERMINAL 3 TO TERMINAL 2 ON TRANSFORMER.
4. START ASSIST FACTORY EQUIPPED WHEN REQUIRED
5. USE COPPER CONDUCTORS ONLY
6. CRANKCASE HEATER AND CRANKCASE HEATER SWITCH FACTORY EQUIPPED WHEN REQUIRED.
7. DOUBLE POLE CONTACTOR SHOWN. SINGLE POLE CONTACTOR COULD BE FACTORY EQUIPPED AS AN ALTERNATE CONFIGURATION.
8. COMMON SIDE OF CONTACTOR CAN NOT BE GROUNDED OR CONNECTED TO ANY OTHER COMMON (24V).

SEE UNIT RATING PLATE FOR TYPE AND SIZE OF OVER CURRENT PROTECTION



0140G01640-E

WARNING
High Voltage: Disconnect all power before servicing or installing this unit. Multiple power sources may be present. Failure to do so may cause property damage, personal injury, or death.

Wiring is subject to change. Always refer to the wiring diagram or the unit for the most up-to-date wiring.

ACCESSORY DESCRIPTION	ITEM NUMBER	
	SMALL CHASSIS	MEDIUM/LARGE CHASSIS
Downflow Economizer (use w/PCCP roof curb)	DDNECNJPCHHA	DDNECNJPCHHA
Downflow Plenum Kit (use w/PCCP roof curb)	PCP101-103	PCP101-103
Downflow Plenum Kit (R-8) (use w/PCCP roof curb)	PCP101-103 R8	PCP101-103 R8
Elbow Flashing w/R-8 Liner	PCEF101-103	PCEF101-103
Economizer Wiring Harness	0259G00215	0259G00215
External Horizontal Filter Rack	DPHFRA	DPHFRA
Horizontal Economizer	DHZECNJPCHM	DHZECNJPCHM
Inline Fuse Kit	INFKPKG01	INFKPKG01
Isolation Relay Kit (req'd with Economizer)	IRKT-01	IRKT-01
Manual Damper	PCMD101-103	PCMD101-103
Manual Damper - Horizontal	GPHMD101-103	GPHMD101-103
Motorized Damper	PCMDM101-103	PCMDM101-103
Outdoor Thermostat & Emergency Heat Relay Kit	OT/EHR18-60	OT/EHR18-60
Outdoor Thermostat Kit w/ Lockout Stat	OT18-60A	OT18-60A
Roof Curb	PCCP101-103	PCCP101-103
Square to Round Downflow (use w/PCCP roof curb)	SQRPC101	SQRPC102-103
Square to Round Horizontal	SQRPCH101	SQRPCH102-103

SINGLE-POINT KIT ACCESSORY KITS

Select the single-point kit accessory based on the unit model.

MODEL	SINGLE-POINT KIT
GPHH32441**	SPK-30
GPHH33041**	SPK-35
GPHH33641**	SPK-40
GPHH34241**	SPK-45
GPHH34841**	SPK-50
GPHH36041**	SPK-60

