

Owner's Guide

Smart Variable Speed Ducted Split Heat Pump (R-410A)



1. HOW IT OPERATES TO KEEP YOU AND FAMILY COMFORTABLE

Congratulations on the purchase of your new InverterCool heat pump system. Your system includes one outdoor unit and one matched indoor unit, which is designed to deliver years of dependable service and performance. Your system will cool and dehumidify the air in your home, and the heat pump heats the air for year round comfort.

As the system circulates and filters air, it also extracts excess moisture from the home to help control humidity in muggy summer months.

Acquaint yourself with your new system by spending just a few minutes with this booklet. Learn about the operation of your system and the small amount of maintenance it takes to keep it operating at peak efficiency.

BE SURE TO SAVE THIS OWNER'S GUIDE.

2. OPERATION

Setting the temperature.

Control your system via the thermostat, place the system mode switch on COOL, and the fan switch on AUTO. Then set the temperature by using the indicator on the thermostat control. Now your system will cool your house whenever the indoor temperature climbs above the thermostat setting. It will shut off when the desired room temperature is reached. In winter, it works the same way. When the system switch is on HEAT, the system will operate whenever the room temperature falls below the temperature setting. Once the desired temperature is reached, the system will shut off.

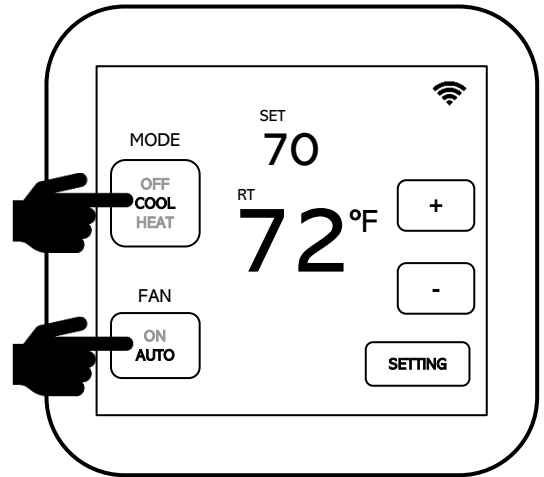

3. HOMEOWNER MAINTENANCE

The heat pump system is not a household appliance. It's a self-contained system that must require professional maintenance and repair. That's why attempts at "do-it-yourself" repairs on an in-warranty unit may void the remainder of your warranty. Other than performing the simple maintenance recommended in this manual, you should not attempt to make any adjustments to your system. Your contractor will be able to take care of any questions or problems you may have.

! CAUTION	! WARNING	! CAUTION
To prevent injury, death, or property damage, read and follow all instructions and warnings, including labels shipped with or attached to unit before operating your new outdoor system.	Disconnect all electrical power to the indoor air handler or furnace before removing access panels to perform any maintenance. Disconnect power to both the indoor and outdoor units. NOTE: There may be more than one electrical disconnect switch. Electric shock can cause personal injury or death.	Although special care has been taken to minimize sharp edges in the construction of your unit, be extremely careful when handling parts or reaching into the unit.

Help ensure top efficiency by cleaning or replacing the filter every 3 months.

When your system circulates the air in your home, dust and dirt particles build up on the filter. Excessive accumulation can block the airflow, forcing the unit to work harder to maintain desired temperatures. And the harder your unit works, the more energy it uses. Recommend to clean or replace your filter monthly during seasons when the unit runs more often.

When replacing your filter(s), always use the same size and type that was originally supplied. Filters are available from your contractor. Where disposable filters are used, they must be replaced with the same size as originally supplied.

How to remove the filter from your Air Handler.

Removing a filter is easy. Make sure you insert the clean filter with the arrows on it pointing in the direction of the airflow. Follow the steps below for the filter change.

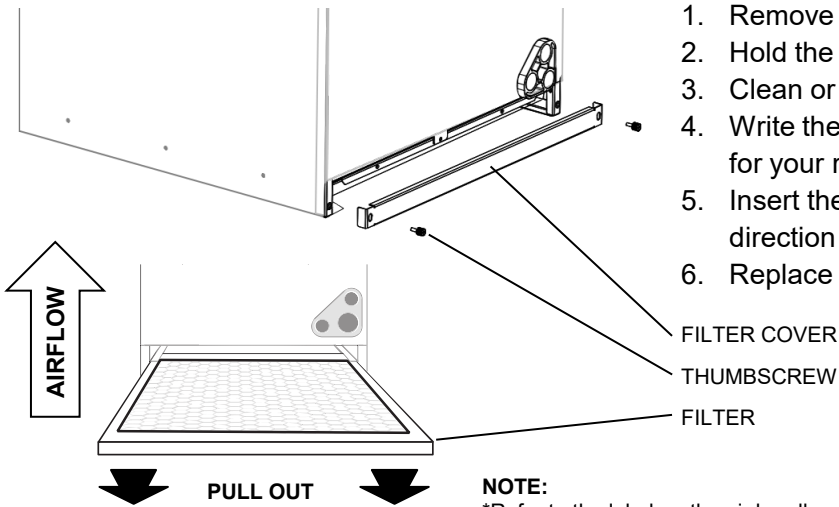

Model Number	Dimensions(inch)
	Filter Size *
24 / 36	18 x 20 x 1
48 / 60	20 x 22 x 1

Efficiency can be maintained by keeping the outdoor unit clear of snow, ice and debris.

Efficient operation of your outdoor unit depends on the free flow of air over the coil. Anything that blocks the airflow causes the compressor to work harder. Buildup of snow and ice can restrict airflow. As soon as possible after accumulation, clean snow from the area around the outdoor unit. To avoid overworking your unit, do not plant flowers or shrubbery right next to it. Also, make sure that nothing is stacked against the sides of the unit or draped over it. Making sure your outdoor unit is kept clear at all times helps it work at peak efficiency. **In the heavy snow area, a snow guard on the top the outdoor unit must be required to protect it,** please contact your contractor for more information.



CAUTION

If heating system is not operational during the cold weather months, provisions must be taken to prevent freeze-up of all water pipes and water receptacles. This is very important during times of vacancy.

4. SEA COAST COIL MAINTENANCE

Coastal locations often require additional maintenance of the outdoor unit due to highly corrosive airborne ocean salt. Although your new InverterCool system is made of galvanized metal and is protected by top-grade paint, take the additional precaution of periodically washing all exposed surfaces and the outdoor coil approximately every 3 months. Consult your contractor for proper cleaning intervals and procedures for your geographic area or ask about a service contract for regularly scheduled professional cleaning and inspections.

5. YEARLY CONTRACTOR MAINTENANCE

In addition to the routine maintenance that you perform, your heat pump system must be inspected regularly by a properly trained contractor. Many contractors offer this service at a reduced rate with a service contract. Some service contracts offer additional benefits such as parts discounts and no additional charge for "after hours" or emergency service.

Your annual system inspection should include:

- Routine inspection of air filter(s) with replacement or cleaning as required
- Inspection and cleaning of the blower wheel housing and motor
- Inspection and, if required, cleaning of indoor and outdoor coils

- Inspection of the indoor coil drain pan, as well as the primary and secondary drain lines. If the system has an auxiliary drain pan and line, they should be inspected at this time as well. Service should include cleaning if required.
- Check all electrical wiring and connections
- Check for secure physical connections of individual parts in each unit
- Operational check of the heat pump system to determine actual working condition. Necessary repair and/or adjustment should be performed.

Call your contractor for additional routine maintenance.

Your outdoor unit must be inspected regularly by a properly trained contractor.

For regular contractor maintenance please refer to <https://www.acca.org/industry/quality>

6. TROUBLESHOOTING



WARNING

ELECTRICAL SHOCK HAZARD

Failure to follow this warning could result in personal injury or death.

Disconnect all electrical power to the indoor air handler or furnace before removing access panels to perform any maintenance. Disconnect power to both the indoor and outdoor units.

NOTE: There may be more than one electrical disconnect switch.

- ❑ Check the indoor and outdoor disconnect switches, it shall be located near your outdoor unit or indoor unit, hanging on the wall. (See the drawing)
- ❑ Check your main electrical panel circuit breakers or fuses.
- ❑ Check for sufficient airflow. Air filter(s) should be reasonably clean and interior vents should be open and unobstructed.
- ❑ Check thermostat settings. For cooling, your desired temperature setting should be LOWER than the displayed room temperature, and the System/Mode control should be on Cool or Auto. For heating, your temperature setting should be HIGHER than the displayed room temperature, and the System/Mode control is set to Heat or Auto.

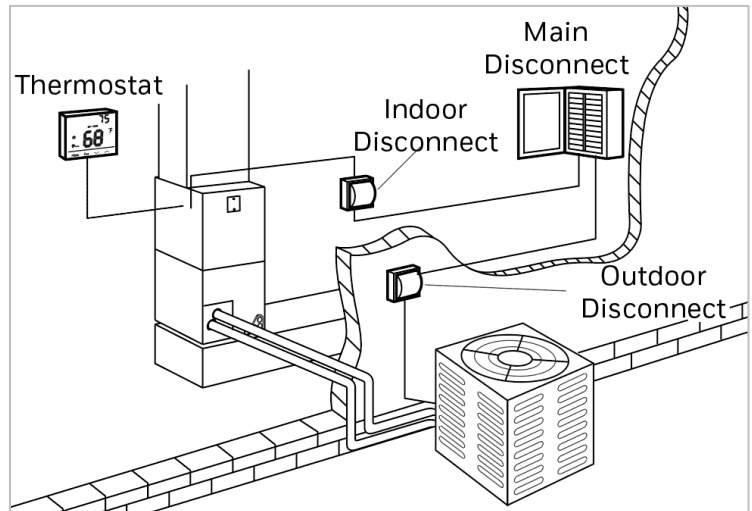

- ❑ Time delays - depending on the InverterCool heat pump you have, there may be delays in unit operation that are built-in to protect the equipment and your comfort. Don't be alarmed if you notice a time delay in operation. It may be a standard protection feature of your equipment. Check with your contractor for more information on time delays.

If you need to contact your contractor for troubleshooting and/or repairs, be sure to have the model and serial numbers of your equipment available. This information can be found on the nameplates of indoor and outdoor unit . Always ask for factory authorized parts for repairs.